

Type 1940

Thread mill with GCT MicroSpeed diamond coating

Applications / Advantages:

- Ideally suited for inner thread in IMS, aluminium and copper
- High dimensional accuracy and process capability due to application-specific design



MicroSpeed diamond coating - Made by GCT in Germany

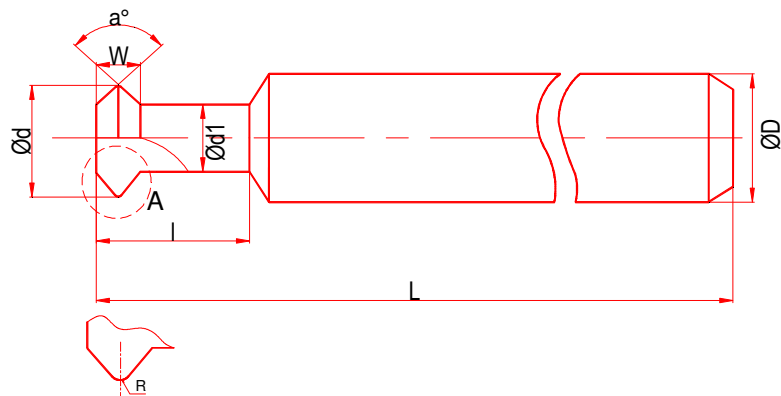

metric thread	l
M1.6 x 0.35 1940 1635 038 7	4.0
M2 x 0.4 1940 2040 038 7	4.0
M2.5 x 0.45 1940 2545 038 7	5.0
M3 x 0.5 1940 3050 038 7	6.0
M4 x 0.7 1940 4070 038 7	6.0
M5 x 0.8 1940 5080 038 7	6.0

Further versions on request.

Standard version:

- shank Ø 3.175mm
- overall length 38.10mm
- tolerances according to GCT router specification
- made of solid carbide

NEW